

# Dual-Frequency Antenna Traps

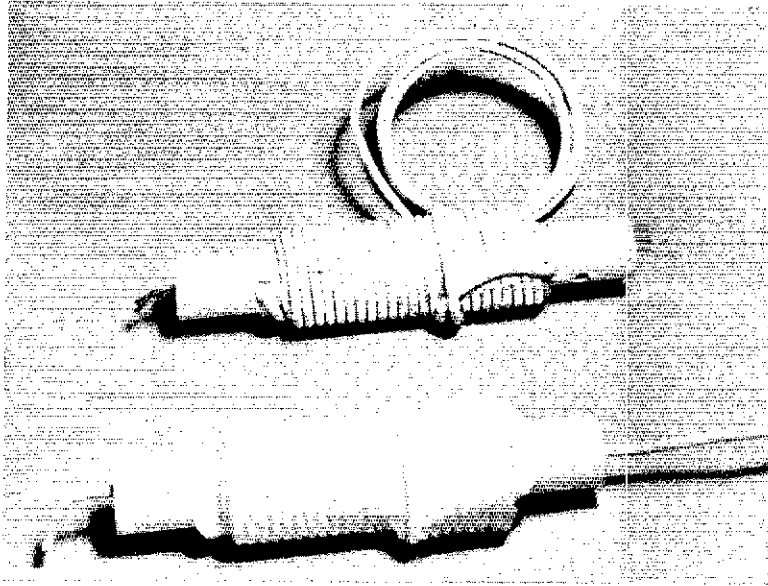

Although L-C antenna traps have been around for years, you've never seen any like these!

By Robert H. Johns,\* W3JIP

Here is a new way to make antenna traps using only coils, without scarce and expensive high-voltage capacitors. An additional bonus is that these traps can be made to resonate simultaneously on two frequencies, greatly expanding their capabilities!

## Cross-Linked Polyethylene (XLP) Insulation

The key to these new traps is a specially insulated wire that withstands several kilovolts. This wire is wound one layer on top of another, which produces some capacitance between the layers (Fig. 1). Enough capacitance in parallel with the coil inductance produces a resonant circuit, which can be used as an antenna trap. In transmitting service, this capacitor (formed by the insulation) will need to withstand high voltage and high currents without much dielectric loss. XLP, a recently developed type of insulation, has

the excellent high-voltage and low-dissipation properties of polyethylene. It is also tough and hard from additional polymerization (or cross linking) of the molecules.

All of the traps described in this article are made from wire covered with XLP insulation. It is normally used for telephone-switchboard service and costs about 10 cents a foot for no. 14 stranded, type-SIS wire.<sup>1,2</sup>

## How They Work

In Fig. 1, notice that the two coils are wound in bifilar fashion. The more turns added to the two coils, the lower the resulting frequency, since inductance and capacitance are increasing simultaneously. This tuned circuit is similar to the filters described by Doty, and is an extension of the coaxial cable traps of O'Neil and Johns.<sup>3,4,5</sup>

A second resonant frequency is achiev-

ed by winding a small *third* layer on top of the first two (Fig. 2). Another tuned circuit is formed by the capacitance between the outermost coil and the two others, together with the inductance of the small coil. This higher-frequency resonance appears only if the third coil is less than half

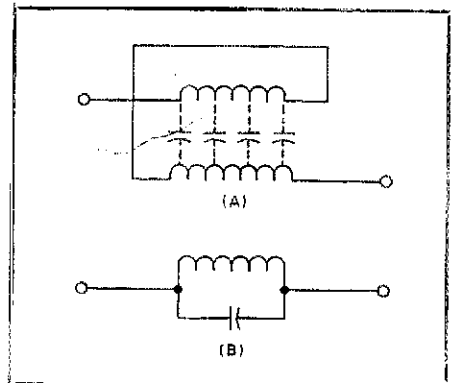

Fig. 1 — Illustration of distributed capacitance between coil turns (A). Electrical equivalent circuit of A (B).

\*Chief Engineer, Barker and Williamson Co., 10 Canal St., Bristol, PA 19007

Notes appear on page 30.

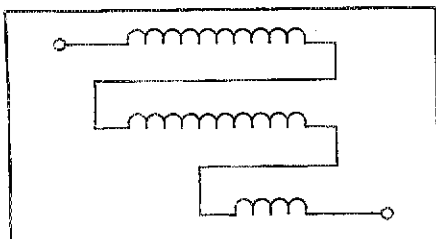

Fig. 2 — A dual-frequency antenna trap. The lower resonant frequency is determined by the entire three-layer coil and distributed capacitance. The higher-frequency resonance is determined by the smallest coil and associated capacitance. The two circuits interact, but can be adjusted individually by varying the number of coil turns.

the length of the larger coils. If too many turns are added, this resonance gets broader and shallower, finally disappearing when the coil becomes too large.

Dual-frequency resonance can be used to good advantage in a trap antenna. The common trap dipole for 80 and 40 meters will also work on 15 meters if the traps are tuned to 21 MHz. The half-wave section on 40 meters will function as three half-wave elements on 15 meters, and can also be fed at the center.

### Construction Principles

The basic trap is a 40/15-meter version, and is made from 1/2-inch PVC pipe. Cut the PVC pipe to 6-inch lengths. One length is needed for each trap. Drill holes in the pipe, as shown in Fig. 3A. The form is now ready to accept the winding.

Start winding the trap by passing a 21-foot length of wire through the center of the form. Pass the ends out through a set of holes spaced 4 inches apart. One end of the wire should protrude approximately 8 feet from the form, the other approximately 13 feet. With the 8-foot wire on your right, wind it toward the left edge of the pipe for a total of 25 1/4 turns (Fig. 3B). Feed the end of the wire through the appropriate hole and out through the center of the trap to form a pigtail. Now coil the other wire on top of the first layer by winding in the opposite direction of rotation, laying each turn in the spaces between first-layer turns (Fig. 3C). Skip a space at the beginning of the second layer, for it has only 23 turns. This coil should finish at the right side of the trap. Feed the remainder of the wire *completely* through the trap form by passing it through two opposing holes.

Take the end of the second-layer wire (there should be about 2 feet left) and lay it perpendicular to the second-layer turns. Count 10 spaces from the right end of the outer coil and make a 90° bend in the wire at this point (Fig. 4). Lay the wire into this space and wind 9 3/4 turns over the second layer, making sure the coil is following the same direction of rotation as the second layer. The third layer is actually wound *over* the wire that lies perpendicular to the

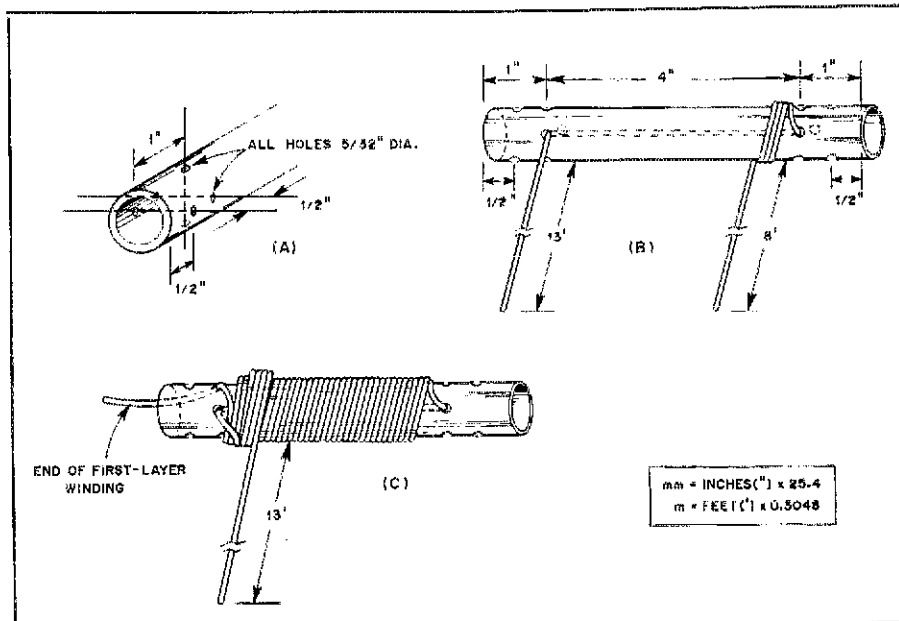

Fig. 3 — Construction details for a 40/15-meter trap. All text instructions follow this orientation of the coil form. Holes should be drilled as shown in A. First-layer coil winding is shown in B, and second-layer details in C.

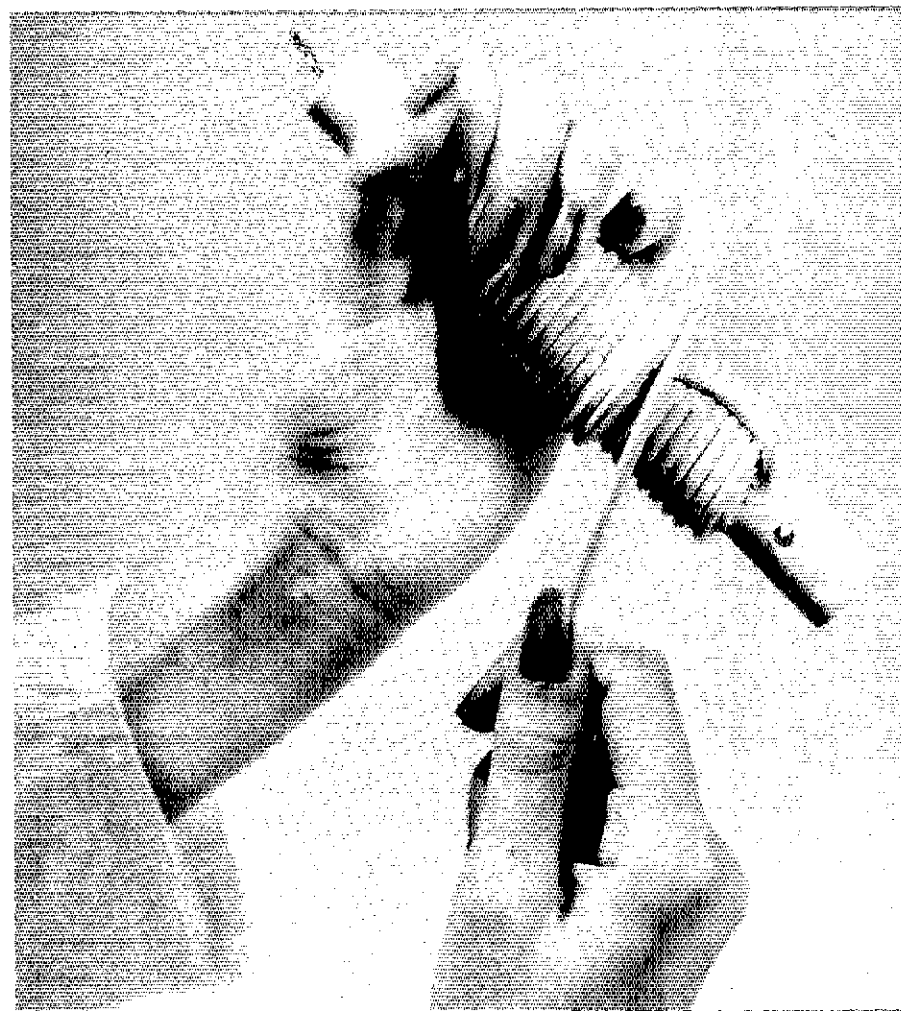

Fig. 4 — The third-layer coil winding technique for a 40/15-meter trap. This coil is wound on top of the wire lying over the second-layer coil.

coils. This outermost coil should end at the right side of the form. Pass the remaining wire through the appropriate hole and out through the center of the trap. You should now have a completed trap with three layers of windings and a pigtail of wire protruding from each end.

### A Four-Band Antenna

Fig. 5 shows the dimensions of a trap dipole using one pair of the 40/15-meter traps described above. It is resonant on 80, 40, 15 and 10 meters.

The 10-meter resonance was a pleasant surprise, and exists because the entire antenna is resonant as five half-wavelengths, capacitively loaded by the traps. The  $1\frac{1}{2}\lambda$  and  $2\frac{1}{2}\lambda$  configurations on 15 and 10 meters, respectively, are not a good match to 50-Ω coaxial cable; a short matching section is used. This is made from the no. 14 SIS wire used in the traps. Two 6-foot pieces of wire lightly twisted together makes a  $\frac{1}{4}\lambda$ , 10-meter transformer (about 130-Ω) that also provides a good match on 15 meters. The matching section is so short that it doesn't affect the 40- and 80-meter bands significantly. The SWR curves of this antenna are shown in Fig. 6.

### Tuning

Here is a tuning trick that can be used with any trap antenna, not just the ones shown here. An insulated wire is passed through or around a trap and capacitively coupled to the antenna wire on either side of the trap (Fig. 7) This effectively places a differential pair of capacitors in parallel with the trap capacitor. The equivalent circuit is shown in Fig. 8. When the tuning wire protrudes equal amounts from both sides of the trap, additional capacitance is at a maximum. In this case, the trap (and antenna) frequency will be brought down to the lowest possible value. Sliding the tuning wire to either side causes the differential pair to decrease in series value, thereby raising the trap (and antenna) resonant frequency. The tuning wire can therefore be slid just far enough to bring the antenna up to the desired resonant frequency.

When the 40/15-meter traps are tuned in this manner, 40 meters is affected the most, with 15 meters affected to a lesser degree. This works out well, since 15-meter resonance is usually quite broad and should not need much adjustment. Although traps should normally be constructed to resonate in the middle of the band, they should resonate at the top of the band when tuning wires are to be used. They will bring resonance back down into the center of the band.

To lower the resonant frequency on 10 and 80 meters, another simple tuning scheme is used. At the ends of the antenna, some of the wire is folded back along itself and then out through a knot at the end (Fig. 9). To lower the resonant frequen-

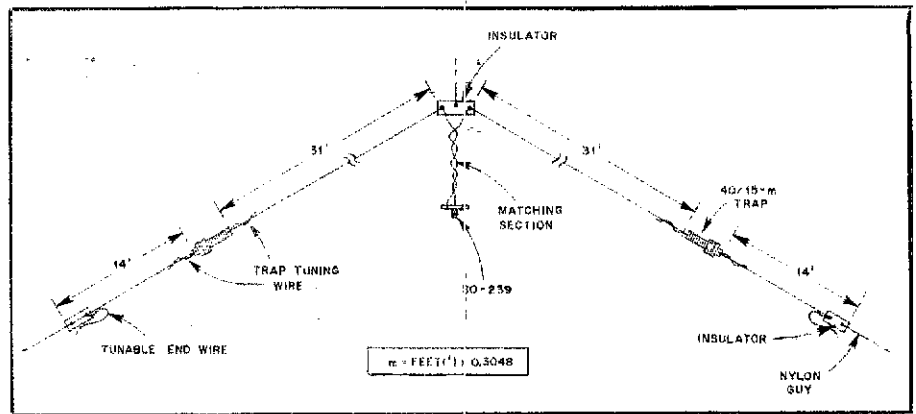

Fig. 5 — Dimensions of an 80/40/15 and 10-meter antenna using one pair of 40/15-meter traps. The center insulator can be made from  $\frac{1}{2}$ -inch PVC pipe, and the SO-239 housing from 1-inch PVC slip caps. The 14-foot dimension includes the length of wire folded back for tuning. See text for details.

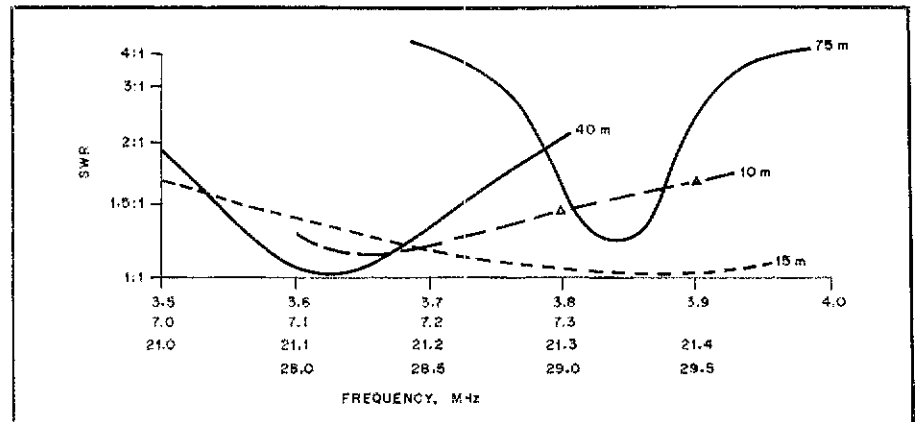

Fig. 6 — SWR curves for the antenna in Fig. 5.

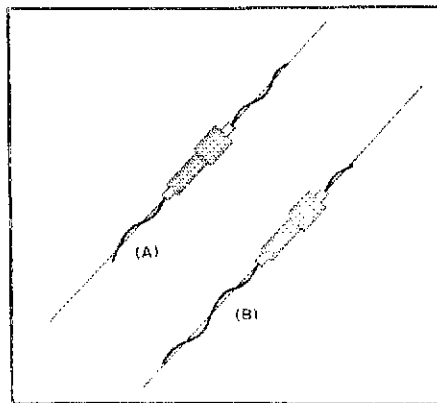

Fig. 7 — The trap-tuning element is a 3-foot length of no. 14, XLP-insulated wire. It is fed through the trap and loosely wrapped around the antenna wire on either side. At A, the capacitance is maximum and the resonant frequency will be lowest. At B, the parallel capacitance has been reduced and the resonant frequency will be higher than in A. A 3-foot wire can tune the antenna over 500 kHz on 40 meters. See text.

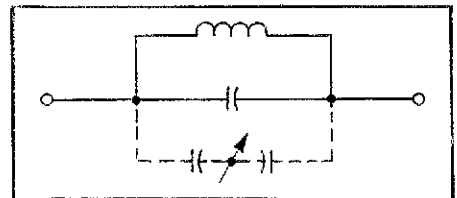

Fig. 8 — Electrical equivalent of a trap and tuning wire. The tuning wire forms a differential capacitor (dashed lines), which changes in series value as the wire is slid through the trap.

V, this adjustment can be made without loosening the guys.

### Other Frequency Combinations

Fig. 10 shows a 10- and 15-meter trap combined with a loading coil to shorten overall antenna length. The long coil is a single layer with a self-resonant frequency of approximately 29 MHz; it also serves as the loading coil. The smaller, second-layer coil forms a 21-MHz trap. The outer portion of the antenna beyond the traps can be cut for any band lower in frequency than 15 meters (except 20 meters). Fig. 11 gives

cy on 10 and 80 meters, some of this wire is pulled out and attached to the nylon guy rope. If the antenna is set up as an inverted

dimensions for a 40/15/10-meter antenna.

This antenna can also be tuned with insulated wires running through the traps. Two wires are used, one into each end of the trap (Fig. 10). The 15-meter tuning is quite critical. A 1/2-inch shift in the tuning wire position moves the resonant frequency across the entire band!

### Last-Minute Hints

When constructing traps, the number of coil turns may need to be adjusted for your particular wire and layout. Typical variations in the insulation thickness are enough to change the number of turns required. A GDO (grid-dip oscillator) is essential when building traps, but don't try to measure the frequency of a trap with any wire connected to it or you will get an erroneous reading. Also, a trap cannot be dipped when it is in an antenna, for too many other resonances will appear. Once a trap is connected into an antenna, all measurements must be done from the feed point. When your traps are completed, wrapping them with electrical tape or dipping them in liquid silicone rubber to secure the turns in place is a good idea. This covering will also help protect the XLP insulation from the damaging effects of ultraviolet radiation.

Many features of the traps and antennas described here have been patented or are patent pending. Amateurs are welcome to build these for their own use, but manufacturers are cautioned that all patent rights will be strictly enforced.

### Notes

<sup>1</sup>m = ft × 0.3048; mm = in. × 25.4.

<sup>2</sup>This wire is available from the local wire distributors and the Barker and Williamson Co., 10 Canal St., Bristol, PA 19007.

<sup>3</sup>A. Dory and A. Macnee, "Introducing the INCONS," *QST*, Feb. 1979, pp. 11-14.

<sup>4</sup>G. O'Neil, "Trapping the Mysteries of Trapped Antennas," *Ham Radio*, Oct. 1981, pp. 10-16.

<sup>5</sup>R. Johns, "Coaxial Cable Antenna Traps," *QST*, May 1981, pp. 15-17.

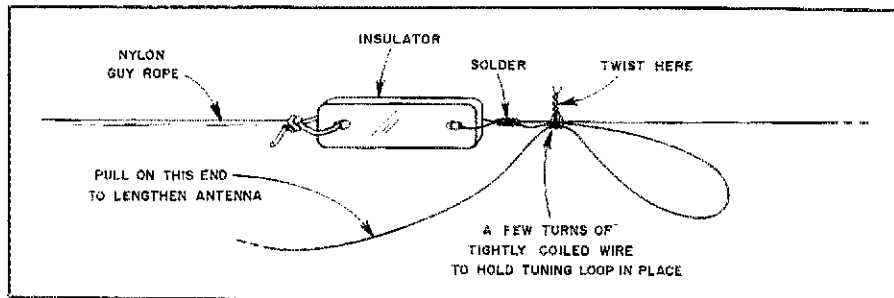

Fig. 9 — Method for tuning 80 and 10 meters on the four-band antenna in Fig. 5. Resonant frequency is lowered by pulling out the free end of the loop.

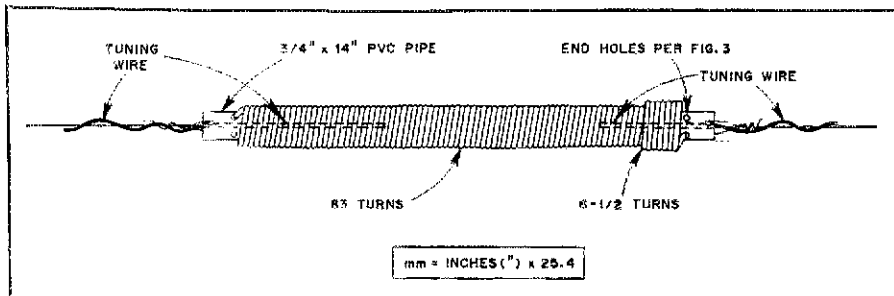

Fig. 10 — Dimensions of the 10/15-meter trap and tuning wires. The trap is wound in the same manner as the 40/15-meter version described in the text. Since this is only a two-layer coil, the end of the first layer is passed completely through the form and laid back over the windings. The second layer is then wound over this wire.

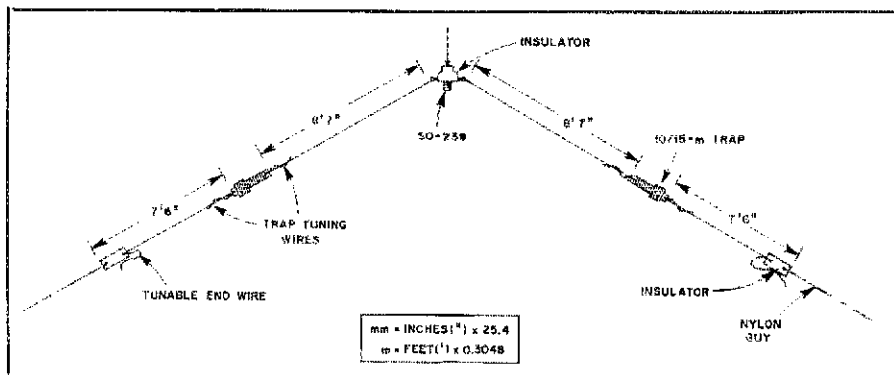

Fig. 11 — A 40/15- and 10-meter antenna using the traps shown in Fig. 10. Because of the loading coils incorporated in the traps, this antenna is approximately half the size of a standard 40-meter dipole.

## New Products

### AVATAR MAGNETICS "GORILLA HOOKS" TOWER CLIMBING ACCESSORY

□ You're 100 feet in the air. It's been a long, hard day installing your new 6-element 20-meter "death ray". Sure, it was a lot of work and you're exhausted. Descending the tower with the setting sun, your mind wanders and you grin in anticipation of those pile ups you're going to breeze through. Suddenly, halfway down the tower, you lose your footing. You scream before realizing that your Gorilla Hooks have saved your life. Instead of breaking your back in a 50-foot fall, you bruise your knee after falling less than 1 foot. After your heart stops beating like a race-car engine at top speed, you finish

your descent in safety and go on to flex your new-found muscles on 14,001 MHz.

Avatar Magnetcs handles a complete line of tower-climbing belts and accessories. The latest addition is the "Gorilla Hook." These hooks snap on to the D-rings of a climbing belt (the same rings the safety strap attaches to). The idea is to alternately attach the Gorilla Hooks to the next-higher tower rung as you climb. The climber is secured to the tower at all times when ascending or descending. In case of a slip, he or she cannot fall more than the Gorilla Hook's cable length.

Gorilla Hooks are made by the Klein Tool Co., a respected manufacturer of high-quality climbing belts. The hooks themselves are made of forged steel and are

attached to belt snaps by a flexible steel cable. The belt snaps must be pressed on both sides to open, preventing them from accidentally unhooking from the belt. Avatar rates the Gorilla Hooks at 4000-lb overall strength.

Although we didn't have the opportunity to hang a 4000-lb gorilla from the hooks, they are easily capable of supporting the weight of a fallen climber. Workmanship is excellent, and a pair of these would be a welcome addition to a tower-climber's accessory collection.

Gorilla Hooks cost \$73 per pair (post-paid to all U.S. ZIP codes), and are available from Avatar Magnetcs Co. (attn: W9JVF), 1147 N. Emerson, Indianapolis, IN 46219. — Mark Wilson, AA2Z